

Preparation

**Part Number: PT18A-35090 (DIO/PPO)**

**Kit Contents**

Item #	Quantity Reqd.	Description
1	1	Stainless Steel Exhaust Tip
2	1	Stainless Steel Clamp Assembly
3	1	Aluminum Bushing
4	1	Installation Instructions

**Hardware Bag Contents**

Item #	Quantity Reqd.	Description
None		

**Additional Items Required For Installation**

Item #	Quantity Reqd.	Description
None		

**Conflicts**

--

**Recommended Tools**

<b>Personal &amp; Vehicle Protection</b>	<b>Notes</b>
None	
<b>Special Tools</b>	<b>Notes</b>
None	
<b>Installation Tools</b>	<b>Notes</b>
<b>Installation Tools</b>	
Ratchet	
Socket	15 mm Deep Well Socket
Torque Wrench	55 N-m
Rubber Mallet	
Non-scratch Cloth	
Wiping Cloth	
<b>Special Chemicals</b>	
Glass Cleaner Approved Cleaner	Dealer Installed VDC Installed

**General Applicability**

--

**Recommended Sequence of Application**

Item #	Accessory
1	Exhaust Tip

\*Mandatory

**Vehicle Service Parts** (may be required for reassembly)

Item #	Quantity Reqd.	Description
1		
2		
3		

**Legend**

 **STOP:** Damage to the vehicle may occur. Do not proceed until process has been complied with.

 **OPERATOR SAFETY:** Use caution to avoid risk of injury.

 **CAUTION:** A process that must be carefully observed in order to reduce the risk of damage to the accessory/vehicle and to ensure a quality installation.

 **TOOLS & EQUIPMENT:** Used in Figures calls out the specific tools and equipment recommended for this process.

 **REVISION MARK:** This mark highlights a change in installation with respect to previous issue.

 **SAFETY TORQUE:** This mark indicates that torque is related to safety.



**Procedure**

Care must be taken when installing this accessory to ensure damage does not occur to the vehicle. The installation of this accessory should follow approved guidelines to ensure a quality installation.

These guidelines can be found in the "Accessory Installation Practices" document.

This document covers such items as:-

- Vehicle Protection (use of covers and blankets, cleaning chemicals, etc.).
- Safety (eye protection, rechecking torque procedure, etc.).
- Vehicle Disassembly/Reassembly (panel removal, part storage, etc.).
- Electrical Component Disassembly/Reassembly (battery disconnection, connector removal, etc.).

Please see your Toyota dealer for a copy of this document.

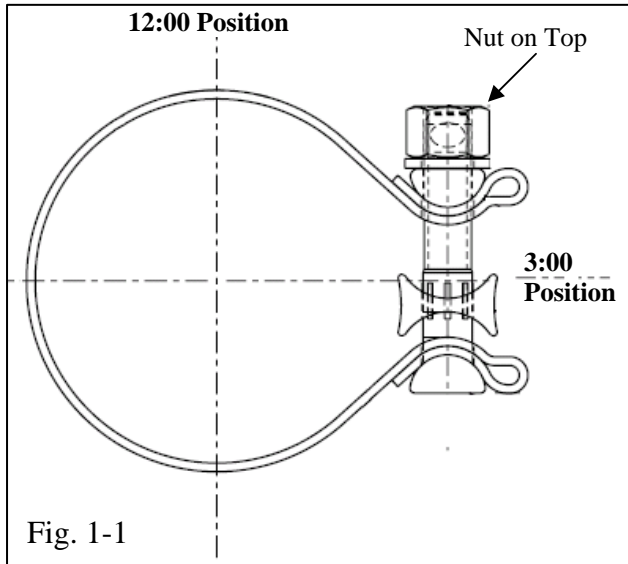

**1. Installation.**

- (a) Make sure the vehicle's tail pipe is free from dirt and debris.
- (b) Remove exhaust tip from box and set on a soft surface to prevent scratching.
- (c) Slide the Stainless Steel clamp over the vehicle tailpipe as shown. (Fig 1-1 & 1-2)



- (1) Locate the bolt of the clamp on the right side (3:00 Position) with the nut on the top as shown. (Fig 1-1)

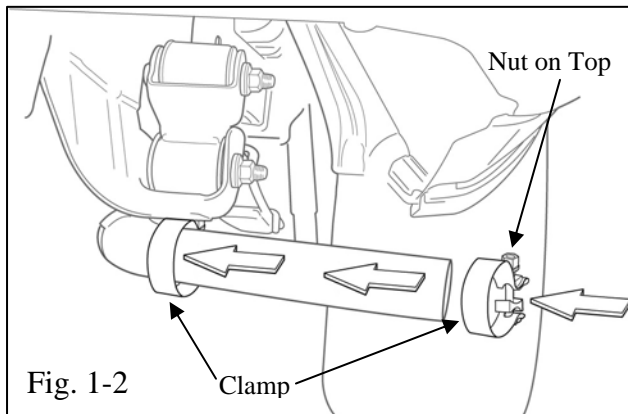

- (2) Continue sliding up out of the way so it won't interfere when you install the exhaust tip and aluminum bushing. (Fig. 1-2)

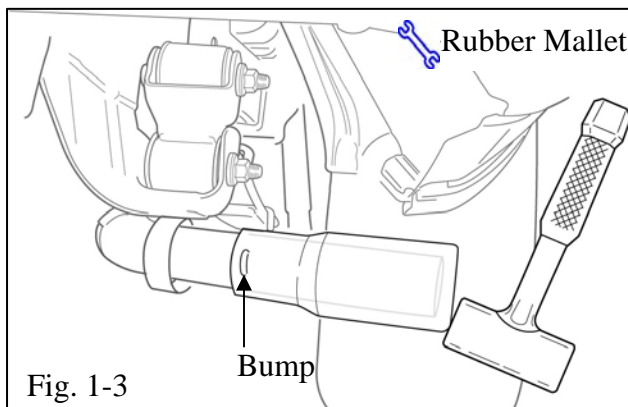

- (d) Slide the exhaust tip over the tail pipe with the bump facing toward the rear of the vehicle as shown. (Fig 1-3)

- (1) If necessary, a rubber mallet may be used to aid installation.

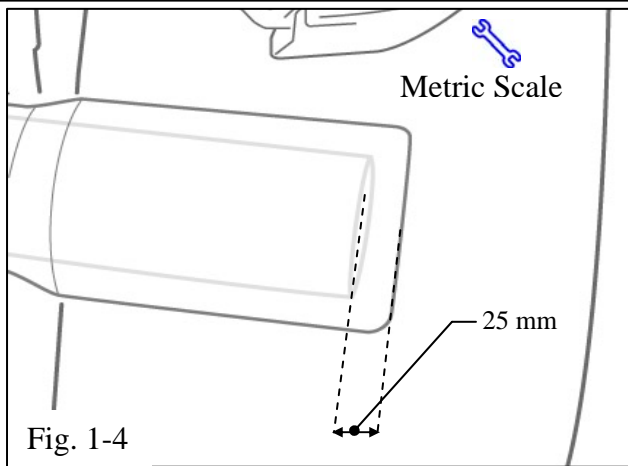

(2) Continue sliding the exhaust tip over the tail pipe until there is approximately a 25 mm distance between the end of the tail pipe and the end of the exhaust tip as shown. (Fig. 1-4)

(e) Insert bushing and position the clamp:  
(Fig. 1-5 & 1-6)

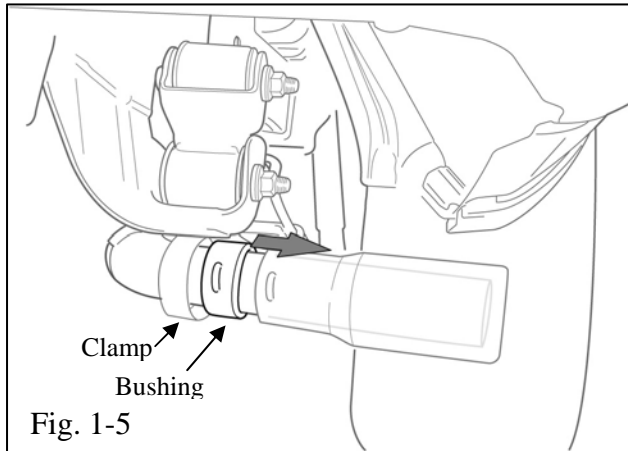

(1) Insert the bushing by aligning the bump on the bushing with the bump stamped into the exhaust tip as shown. (Fig. 1-5)

(2) Slide the clamp onto the exhaust tip behind the bump with the bolt on the right side and the nut facing up. (Fig. 1-6 & 1-7)



**NOTE:** Make sure that the clamp is located behind the bump on the exhaust tip. The bump is designed to prevent the clamp from sliding off the exhaust tip. (Fig. 1-6)

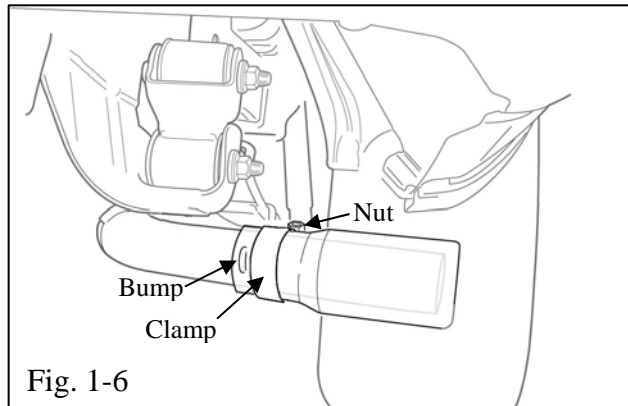

(f) Once the tip is positioned correctly and the alignment seems accurate, tighten the clamp nut making sure the bolt remains in a vertical 3:00 position. (Fig.1-7)



(g) Torque clamp nut to 55 N-m (40.5 ft-lbf)



**Torque: 55 Nm (40.5 ft-lbf)**

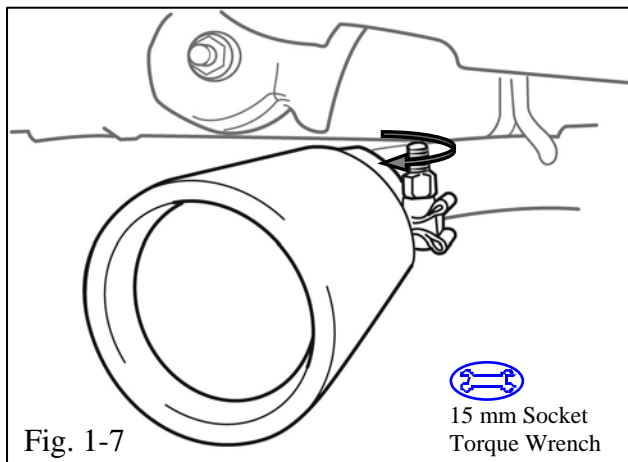

(h) Clean exhaust tip with glass cleaner or approved cleaner and non-scratching cloth

**TOYOTA TACOMA 2005 - STAINLESS STEEL EXHAUST TIP**  
Checklist - these points **MUST** be checked to ensure a quality installation.

<u>Check:</u>	<u>Look For:</u>
<p><u>Accessory Function Checks</u></p> <ul style="list-style-type: none"><li><input type="checkbox"/> Correct part number has been installed.</li><li><input type="checkbox"/> Clamp Alignment</li> <li><input type="checkbox"/> Tip Position</li></ul>	<p>Verify part number on package.</p> <p>Clamp should be oriented behind the bump with the bolt on the right side @ 3:00 position with nut on top.</p> <p>Tip should be positioned with the bump facing to the rear of the vehicle.</p> <p>There should be approximately a 25 mm distance between the end of the tail pipe and the end of the exhaust tip.</p>
<p><u>Vehicle Function Checks</u></p> <ul style="list-style-type: none"><li><input type="checkbox"/> Rattle or vibration</li></ul>	<p>Start engine and check for rattle or vibration of exhaust tip.</p>
<p><u>Vehicle Appearance Check</u></p> <ul style="list-style-type: none"><li><input type="checkbox"/> After accessory installation and removal of protective cover(s), perform a visual inspection.</li></ul>	<p>Ensure no damage (including scuffs and scratches) was caused during the installation process. (For PPO installations, refer to TMS Accessory Quality Shipping Standard.)</p>